

Schutzvermerk ISO 16016 beachten

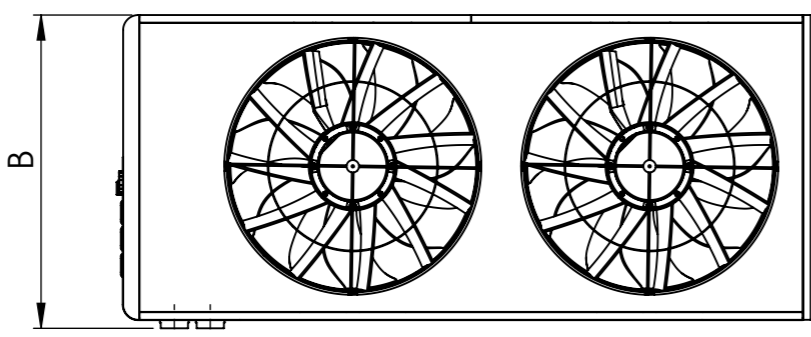

A	1840	
B	830	
C	2030	
D	1685	inlet
E	175	standard
F	1590	outlet
G	240	standard
H	155	optional
I	325	optional / tank level equalization
J	390	optional
K	G 2''	cold water connection
L	1730	power supply
M	125	power supply
N	1640	power supply
O	65	power supply
P	∅ 48	power supply

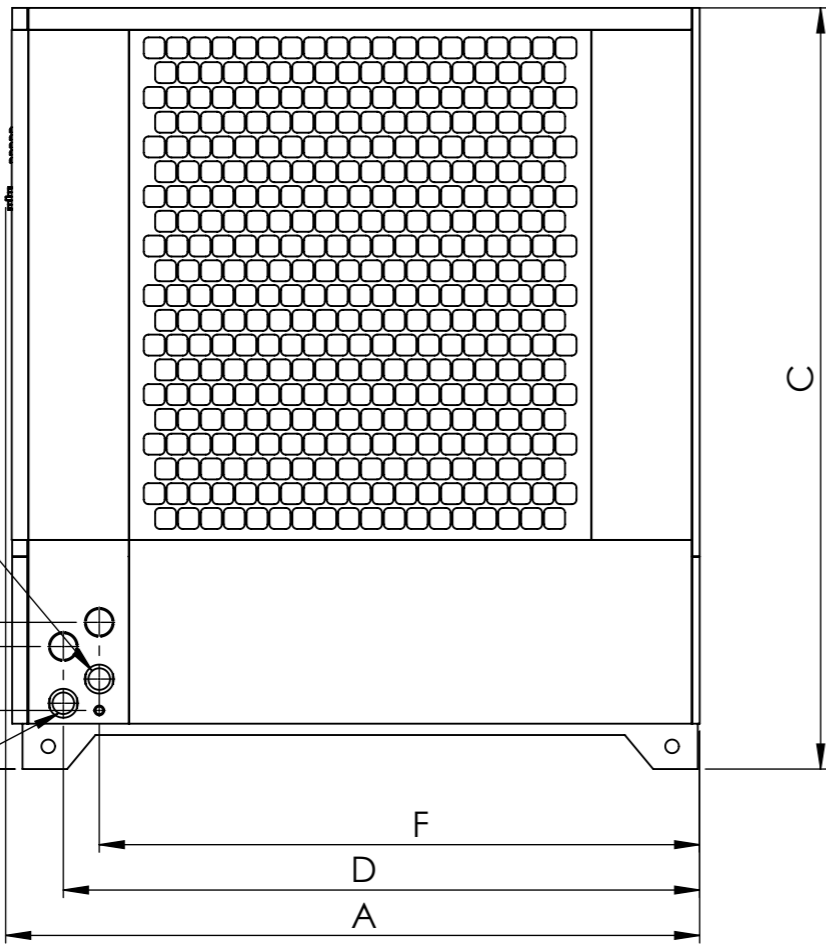
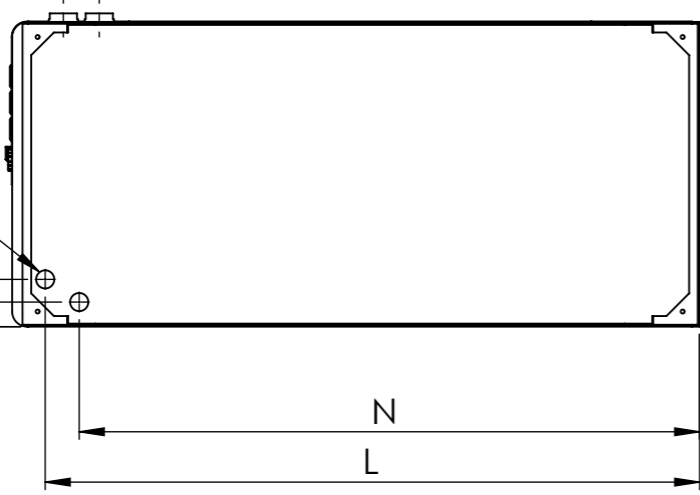
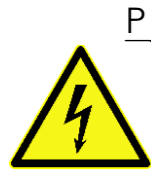
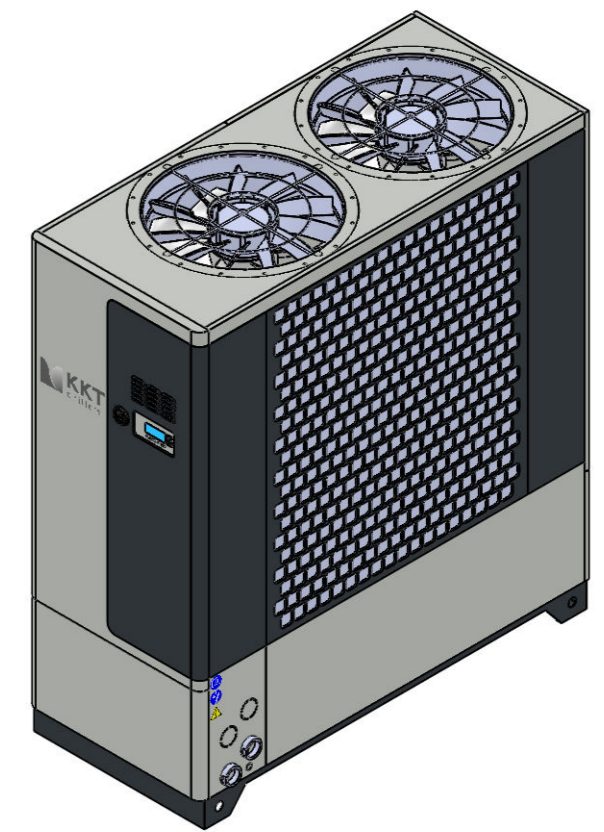
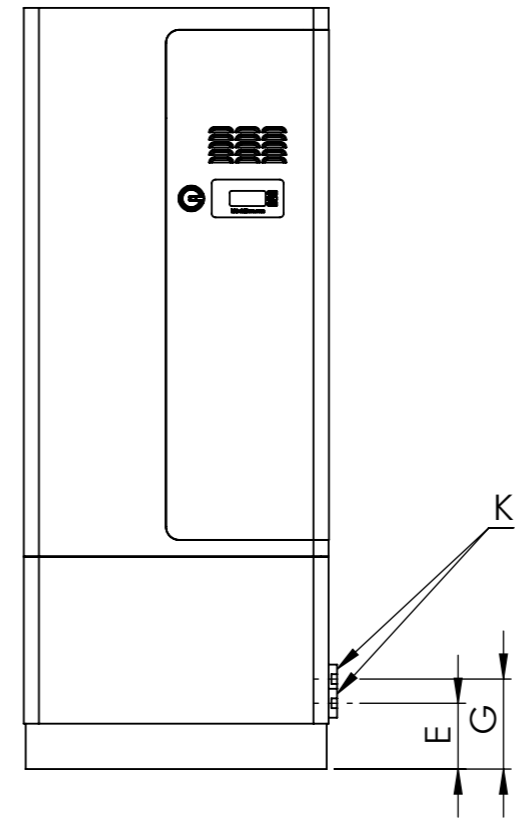

All dimensions in mm!

Compact Line

 KKT chillers - a brand of ait-deutschland GmbH	Allgmein- toleranz DIN ISO 2768 -cL	Oberflächen	Maßstab 1:20	Det. Maßstab 1:25
	Datum	Name	Werkstoff	Gewicht
Erstellt 21.11.2014	Gepr.	Norm.	Benennung Abmessungen cBoxX70-100 luftgekühlt main dimensions cBoxX70-100 aircooled	
b Piktogramme 21.11.2014HH	a ait-deutschland GmbH 11.2014HH	ait-deutschland GmbH Industriestraße 3 D - 95359 Kasendorf www.ait-deutschland.eu	ArtikelNr. 81900601.K	Blatt 1 von 1
Zust.	Änderungstext	Datum	Von	Ers. f. C6850-02Rev01 Ers. d.

Blattformat: A3 quer